

General Safety Information

WARNING – To avoid serious injuries:

- Improper use of your bicycle's brake system may result in a loss of control or an accident, which could lead to a severe injury. Because each bicycle may handle differently, be sure to learn the proper braking technique (including brake lever pressure and bicycle control characteristics) for your bicycle. Consult your bicycle dealer and the bicycle's owners manual, and practice your riding and braking technique.
- Brakes designed for use as rear brakes should not be used as front brakes.
- Obtain and read the service instructions carefully prior to installing the parts. Loose, worn or damaged parts may cause the bicycle to fall over and serious injury may occur as a result. We strongly recommend only using genuine Shimano replacement parts.
- Be careful not to allow any oil or grease to get onto the brake shoes. If any oil or grease do get on the shoes, you should replace the shoes, otherwise the brakes may not work correctly.
- Check the brake cable for rust and fraying, and replace the cable immediately if any such problems are found. If this is not done, the brakes may not work correctly.
- Always make sure that the brakes are working correctly before you ride the bicycle.
- The required braking distance will be longer during wet weather. Reduce your speed and apply the brakes early and gently.
- If the road surface is wet, the tires will skid more easily. If the tires skid, you may fall off the bicycle. To avoid this, reduce your speed and apply the brakes early and gently.
- Read these Technical Service Instructions carefully, and keep them in a safe place for later reference.

Shimano BR-MX70 Safety Information

WARNING – To avoid serious injuries:

Use the BR-MX70 V-BRAKE brake with V-BRAKE brake-compatible brake levers such as the BL-MX70 brake levers.

Note

- The BR-MX70 V-BRAKE brake can only be used as a rear brake.
- The optimum efficiency of the Multi-Condition Brake System can be realized by using the brakes and brake levers in the recommended set.
- If the brake shoes have worn down until the grooves are no longer visible, they should be replaced.
- Parts are not guaranteed against natural wear or deterioration resulting from normal use.
- For maximum performance we highly recommend Shimano lubricants and maintenance products.
- For any questions regarding methods of handling or maintenance, please contact the place of purchase.

Technical Service Instructions

SI-8ED0A-001

Multi-Condition Brake System

Multi-Condition Brake System

By providing superior wet weather braking performance (control and modulation), braking performance will not vary in a multitude of conditions when using this brake system.

In order to realize the best performance, we recommend that the following combination be used.

Series	DXR
Brake lever	BL-MX70
V-BRAKE brake	BR-MX70
Brake cable	

Installation of the brake lever

Use a 5 mm Allen key to install the brake lever.

Tightening torque:
6 – 8 N·m {52 – 69 in. lbs.}

Use a handlebar grip with a maximum outer diameter of 32 mm.

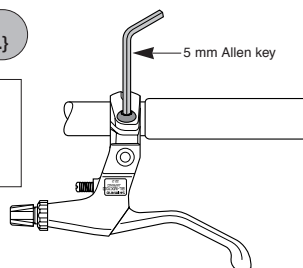

When installing the components to carbon frame/handle bar surfaces, verify with the manufacturer of the carbon frame/parts for their recommendation on tightening torque in order to prevent over tightening that can cause damage to the carbon material and/or under tightening that can cause lack of fixing strength for the components.

Installation of the V-BRAKE brake

1. Insert the stopper pin of the brake body into the center spring hole in the frame mounting boss, and then secure the brake body to the frame with the link fixing bolt.

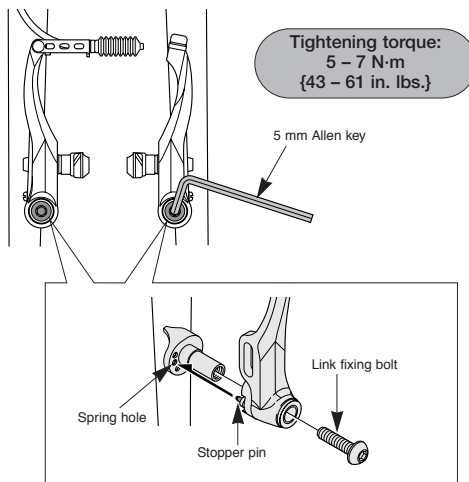

2. While holding the shoe against the rim, adjust the amount of shoe protrusion by changing over the washer B (thick or thin) so that dimension A is kept at 32 mm or more.

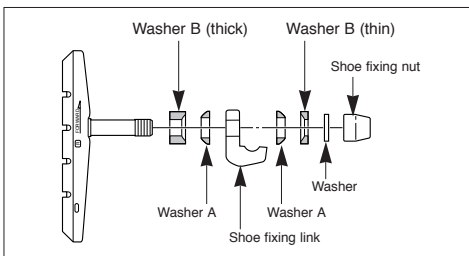
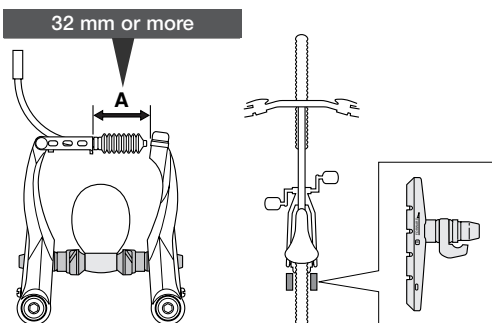

3. While holding the shoe against the rim, tighten the shoe fixing nut.

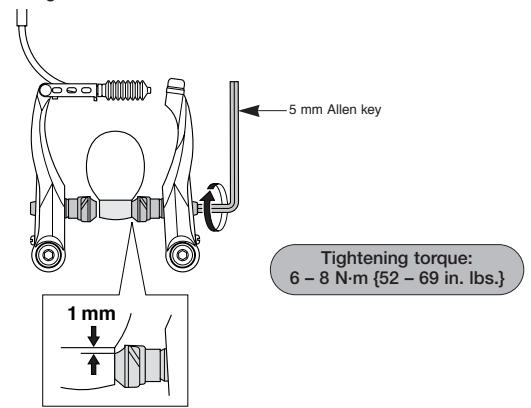

4. Pass the inner cable through the inner cable lead, and after setting so that the total of the clearances between the left and right shoes and the rim is 2 mm, tighten the cable fixing bolt.

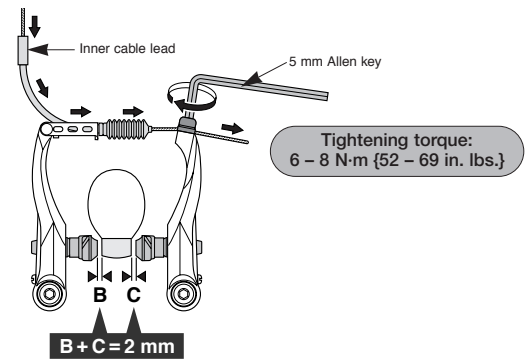

5. Adjust the balance with the spring tension adjustment screws.

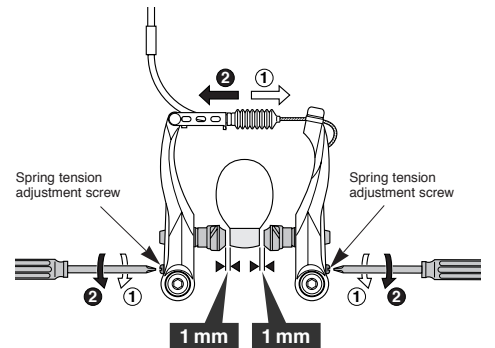

6. Depress the brake lever about 10 times as far as the grip and check that everything is operating correctly and that the shoe clearance is correct before using the brakes.

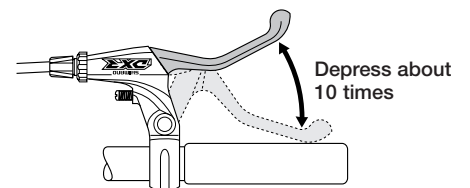

Replacement of the cartridge shoe

1. Remove the shoe fixing pin, and then slide the shoe along the groove to remove it from the shoe holder.

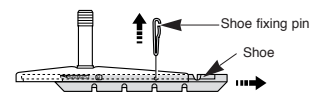

2. There are two different types of shoe and shoe holder to be used in the left and right positions respectively. Slide the new shoes into the grooves on the shoe holders while taking note of the correct directions and pin hole positions.

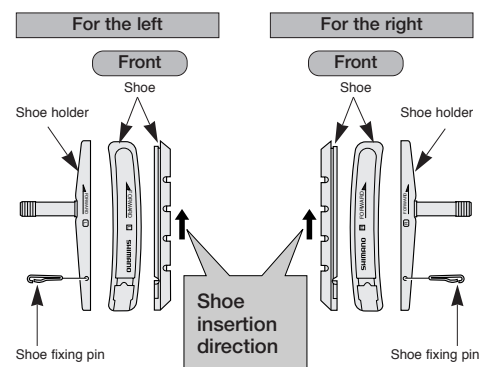

3. Insertion of shoe fixing pin is very critical to keep shoe properly fixed in place.

SHIMANO

SHIMANO AMERICAN CORPORATION
One Holland, Irvine, California 92618, U.S.A. Phone: +1-949-951-5003

SHIMANO EUROPE B.V.
Industrieweg 24, 8071 CT Nunspeet, The Netherlands Phone: +31-341-272222

SHIMANO INC.
3-77 Oimatsu-cho, Sakai-ku, Sakai-shi, Osaka 590-8577, Japan

Please note: specifications are subject to change for improvement without notice. (English)
© Jun. 2008 by Shimano Inc. XBC IZM Printed in Malaysia.