

## General Safety Information

### WARNING

- Check that the wheels are fastened securely before riding the bicycle. If the wheels are loose in any way, they may come off the bicycle and serious injury may result.
- Before use, check the wheels to make sure that there are no bent or loose spokes, dents, scratches or cracks on the rim surface. Do not use the wheel if any of these problems are found.
- The wheel is designed for cross-country riding. Do not use it for downhill riding, otherwise the wheel may become bent or otherwise damaged, and accidents may occur as a result.
- If the quick release mechanism is not used correctly, the wheel may come off the bicycle and serious injury could result. Read the Service Instructions for the quick release mechanism thoroughly before use.
- These wheels are designed exclusively for use with disc brakes. Do not use these wheels with rim brakes.
- Be sure to carefully read the Service Instructions for the disc brakes also.
- Obtain and read the service instructions carefully prior to installing the parts. Loose, worn, or damaged parts may cause injury to the rider.
- We strongly recommend only using genuine Shimano replacement parts.
- Read these Technical Service Instructions carefully, and keep them in a safe place for later reference.

### CAUTION

- Do not use rim tape. Rim tape may make it difficult to remove and install the tire, and the tire or tube may become damaged or the tires may suddenly puncture and come off, and severe injury may result.

### CAUTION

- Use genuine Shimano spokes, nuts, plugs and washers, otherwise damage to the rim and hub unit may result.
- The air pressure should be within the range of 200-400 kPa (29-58 psi).
- Be careful not to overtighten the plugs when adjusting the spoke tensions. If the plugs are overtightened, damage to the rim may result. (We recommend that you ask authorized bicycle dealers to make the adjustments.)
- Puncture repair agents and puncture prevention agents may corrode the rims, so only use neutral-type agents.

### Note

- If the wheel becomes stiff and difficult to turn, you should lubricate it with grease.
- Do not apply any oil to the inside of the hub, otherwise the grease will come out.
- Special spoke wrenches are available as optional accessories.
- We recommend that you ask authorized bicycle dealers to adjust the spoke tensions if there is any initial play in the spokes and after the first 1,000 km of riding.
- Do not use detergents or chemical cleaners to wipe the wheel, otherwise they may cause the air sealant that has been applied to the joints in the rim to peel off.
- Do not use detergent or other chemicals when wiping the wheel, otherwise it may cause the sticker on the rim to peel off.
- Reflectors are also sold separately. Please ask your bicycle dealer for details.

#### <WH-M775>

Model number	Specification	Color
RR-550-WUW SW W/O BRACKET	JIS / CPSC	White
RR-550-WUA SW W/O BRACKET	AS	Amber
RR-317-WUA SW W/O BRACKET	DIN	Amber

#### <WH-MT75>

Model number	Specification	Color
RR-550-WUW SW	JIS / CPSC	White
RR-550-WUA SW	AS	Amber
RR-317-WUA SW	DIN	Amber

- Spoke protectors are also sold separately. Please ask your bicycle dealer for details.

CP-WH14	CS-M970
CP-WH15	CS-M770

- For maximum performance we highly recommend Shimano lubricants and maintenance products.
- Parts are not guaranteed against natural wear or deterioration resulting from normal use.

## Technical Service Instructions

SI-4DA0B-001

### WH-M775 WH-MT75

Wheel

In order to realize the best performance, we recommend that the following combination be used.

Chain	CN-7701 / CN-HG93 / CN-HG73
Cassette sprocket	CS-M770 / CS-M970
Rotor	SM-RT78 / SM-RT97

## SHIMANO

SHIMANO AMERICAN CORPORATION  
One Holland, Irvine, California 92618, U.S.A. Phone: +1-949-951-5003

SHIMANO EUROPE B.V.  
Industrieweg 24, 8071 CT Nunspeet, The Netherlands Phone: +31-341-272222

SHIMANO INC.  
3-77 Oimatsu-cho, Sakai-ku, Sakai-shi, Osaka 590-8577, Japan

Please note: specifications are subject to change for improvement without notice. (English) © Jan. 2008 by Shimano Inc. XBC IZM Printed in Malaysia.

## Specifications

Model number	WH-M775	WH-MT75
Speeds	9	9
No. of spokes	24	24
Rim width	23.3 mm	23.3 mm
Rim size	26"	29"
Applicable tire size	26 x 1.5 ~ 2.25	29 x 1.5 ~ 2.25
Applicable brakes	Disc brake	Disc brake

## Replacing the spokes

- Pass the washer and plug over the spoke.
- After inserting the spoke into the hole in the hub flange, tighten the nut. When installing, use the spoke stopper to secure the spoke so that it does not turn, and then insert a screwdriver or similar tool into the groove in the nut to screw in the nut.
- Turn the plug clockwise to screw it into the screw hole in the rim.

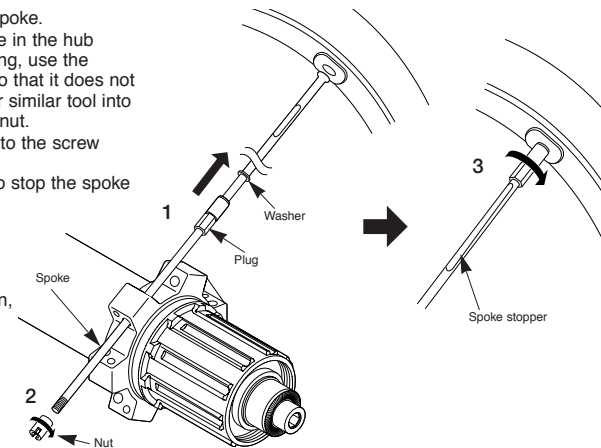

### Note:

- If the washer is not installed, it will not be possible to adjust the spoke tension, so be sure to include the washer.
- Tighten the nut as far as the edges of the thread.

## Spoke lacing

Lace the spokes as shown in the illustration.

### For front

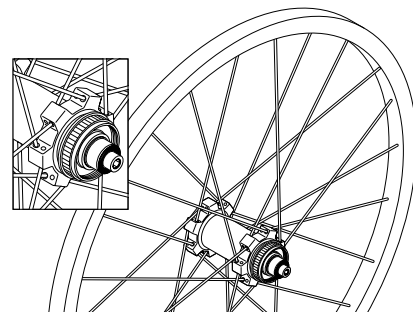

### For rear

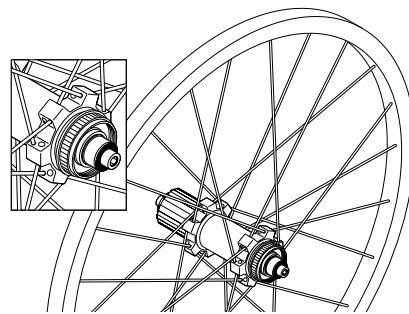

### Spoke tension value

For front		For rear	
Right side	Left side	Right (sprocket) side	Left side
600 - 1000 N (135 - 225 lbf)	900 - 1350 N (202 - 304 lbf)	900 - 1350 N (202 - 304 lbf)	600 - 1000 N (135 - 225 lbf)

\* These values should be used as a guide only.

## Maintenance

The unit can be disassembled as shown in the illustration. Apply grease to the various parts at periodic intervals.

### Note:

- The front hub cannot be disassembled from the left side of the hub unit (the rotor fixing serration side).
- When removing and installing the seal, do it very carefully so that the seal does not become bent.
- When reinstalling the seal, make sure that it is facing the right way, and insert it as far as it will go.

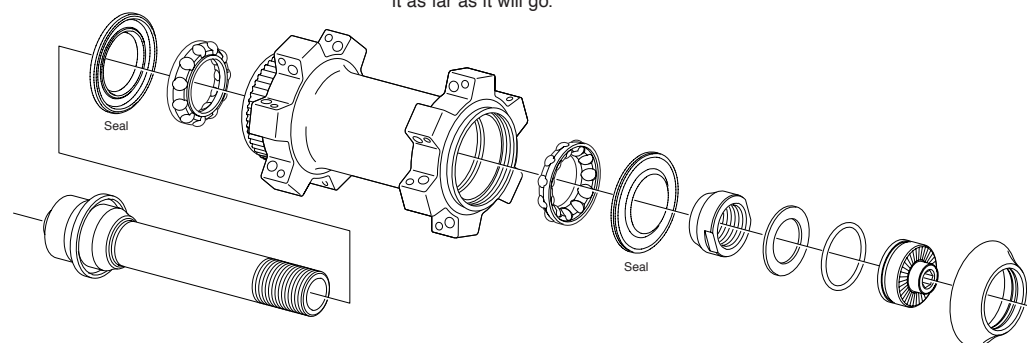

## Installation of the HG sprockets

For each sprocket, the surface that has the group mark should face outward and be positioned so that the wide parts of the gear projections on each sprocket and the A part (where the groove width is wide) of the freewheel body are aligned.

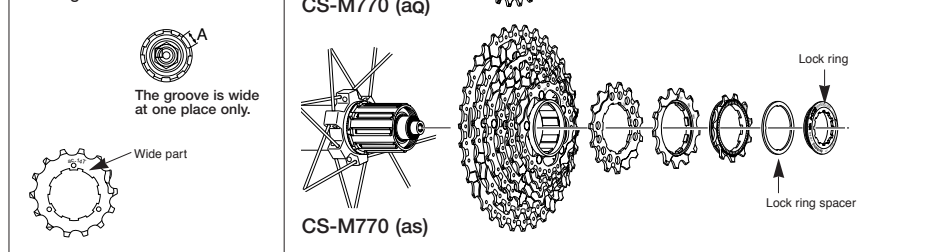

For installation of the HG sprockets, use the special tool (TL-LR15) to tighten the lock ring.

Tightening torque:  
30 - 50 N·m (261 - 434 in. lbs.)

To replace the HG sprockets, use the special tool (TL-LR15) and TL-SR21 to remove the lock ring.

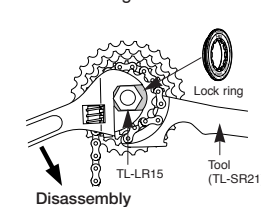

## Replacement of the freewheel body

- First, pull out the hub axle by following the procedure shown in the illustration. The double-lock section at the freewheel side cannot be disassembled.

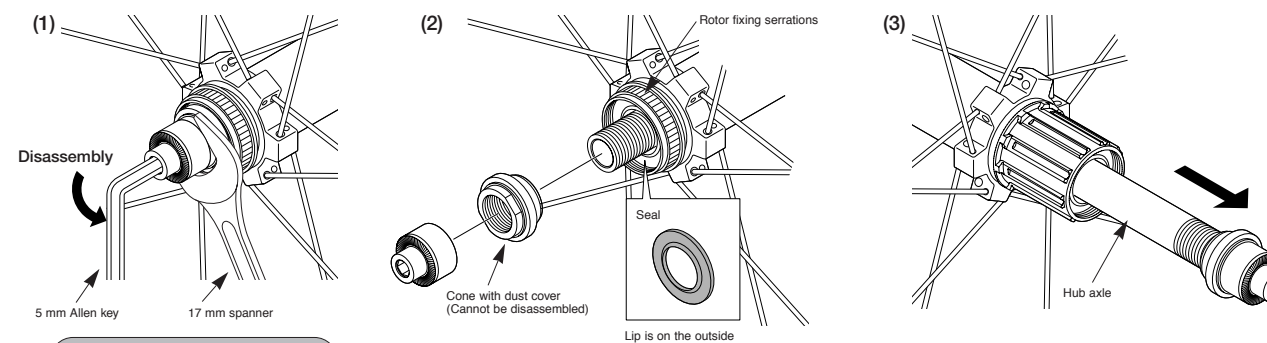

Left side Tightening torque:  
15 - 20 N·m (132 - 172 in. lbs.)

### Note:

- When removing and installing the seal, do it very carefully so that the seal does not become bent. When reinstalling the seal, make sure that it is facing the right way, and insert it as far as it will go.
- Do not disassemble the dust-proof cover which is crimped onto the cone.

- After removing the hub axle, remove the freewheel body fixing bolt (inside the freewheel body), and then replace the freewheel body.

### Note:

- Be sure to apply grease to the thread of the freewheel body fixing bolt, otherwise looseness or sticking may occur. Do not attempt to disassemble the freewheel body, because it may result in a malfunction.

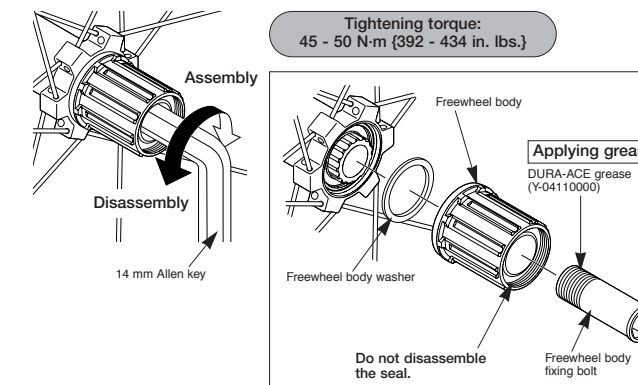

Tightening torque:  
45 - 50 N·m (392 - 434 in. lbs.)

Do not disassemble the seal.

## Installation of the rotor

<Assembly>  
Use a 17 mm spanner and a 5 mm Allen key to tighten the lock nut so as to double-lock the hub axle mechanism as shown in the illustration.

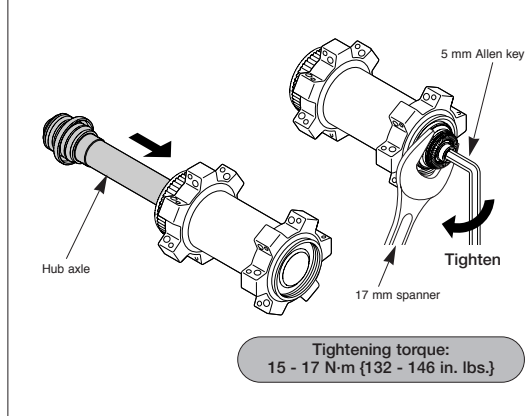

Tightening torque:  
15 - 17 N·m (132 - 146 in. lbs.)

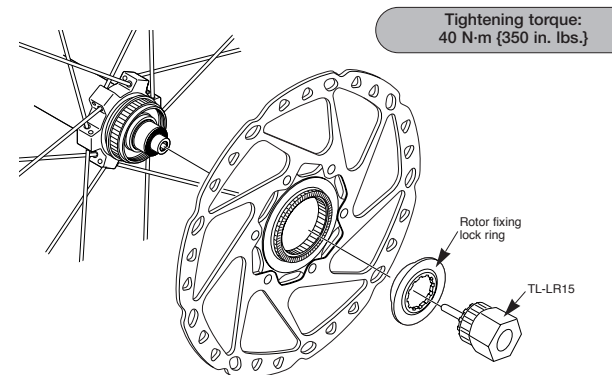

Tightening torque:  
40 N·m (350 in. lbs.)