

General Safety Information

WARNING

- Check that the wheels are fastened securely before riding the bicycle. If the wheels are loose in any way, they may come off the bicycle and serious injury may result.
- Obtain and read the service instructions carefully prior to installing the parts. Loose, worn, or damaged parts may cause injury to the rider.
- We strongly recommend only using genuine Shimano replacement parts.
- Read these Technical Service Instructions carefully, and keep them in a safe place for later reference.

Note

- Use the CS-M970 in combination with 9-speed chains (CN-7701 / HG93 / HG73 / HG53).
- An 11T and a 12T lock ring are available for use with the CS-M970. Use whichever lock ring matches the sprocket configuration.
- If the wheel becomes stiff and difficult to turn, you should lubricate it with grease.
- Do not apply any oil to the inside of the hub, otherwise the grease will come out.
- You should periodically wash the sprockets in a neutral detergent and then lubricate them again. In addition, cleaning the chain with neutral detergent and lubricating it can be an effective way of extending the useful life of the sprockets and the chain.
- If the chain keeps coming off the sprockets during use, replace the sprockets and the chain.
- Parts are not guaranteed against natural wear or deterioration resulting from normal use.
- For maximum performance we highly recommend Shimano lubricants and maintenance products.

Technical Service Instructions

SI-3CP0A

FH-M975 / FH-M970 HB-M975 / HB-M970

Freehub / Front hub

Specifications

Freehub / Front hub

Model No.	Freehub		Front hub	
	FH-M975	FH-M970	HB-M975	HB-M970
Gears	9		—	
No. of spoke holes	32 / 36		28 / 32 / 36	
Overlock nut dimensions	135 mm		100 mm	
Applicable brakes	Disc brake	Rim brakes	Disc brake	Rim brakes

Cassette sprocket tooth combination

Model number	Group name	Gears	Tooth combination
CS-M970	ba	9	11, 12, 14, 16, 18, 21, 24, 28, 32T
	bd	9	12, 14, 16, 18, 20, 23, 26, 30, 34T
	be	9	11, 13, 15, 17, 20, 23, 26, 30, 34T

SHIMANO

SHIMANO AMERICAN CORPORATION
One Holland, Irvine, California 92618, U.S.A. Phone: +1-949-951-5003

SHIMANO EUROPE B.V.
Industrieweg 24, 8071 CT Nunspeet, The Netherlands Phone: +31-341-272222

SHIMANO INC.
3-77 Oimatsu-cho Sakai-ku, Sakai, Osaka 590-8577, Japan

These service instructions are printed on recycled paper.
Please note: specifications are subject to change for improvement without notice. (English)
© May 2006 by Shimano Inc. XBC SZK Printed in Japan.

<FH-M975 / FH-M970>

Installation of the HG sprockets

For each sprocket, the surface that has the group mark should face outward and be positioned so that the wide parts of the gear projections on each sprocket and the A part (where the groove width is wide) of the freewheel body are aligned.

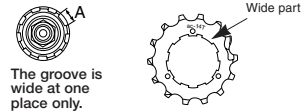

For installation of the HG sprockets, use the special tool (TL-LR15) to tighten the lock ring.

Tightening torque:
30 - 50 N·m {261 - 434 in. lbs.}

To replace the HG sprockets, use the special tool (TL-LR15) and TL-SR21 to remove the lock ring.

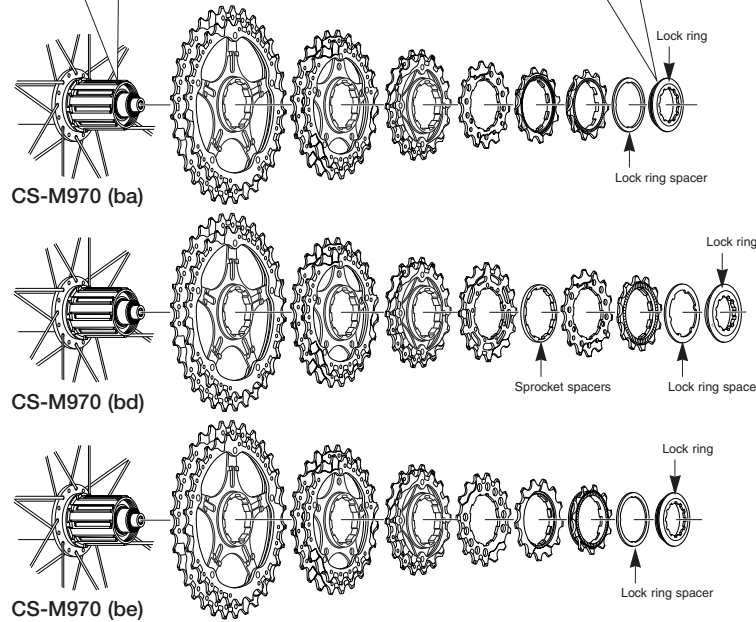
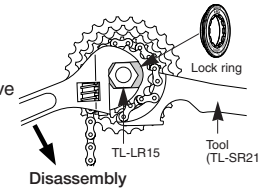

Replacement of the freewheel body

First, pull out the hub axle by following the procedure shown in the illustration. The double-lock section at the freewheel side cannot be disassembled.

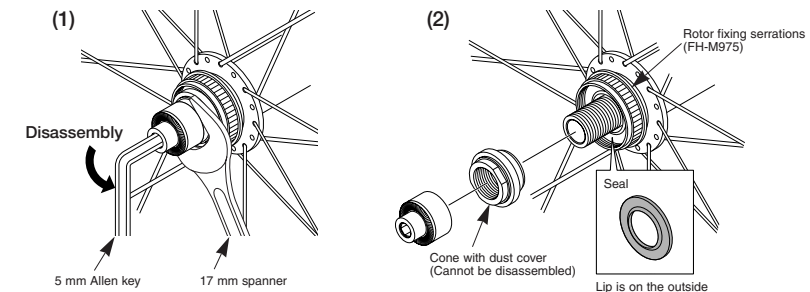

Left side Tightening torque:
15 - 20 N·m {132 - 172 in. lbs.}

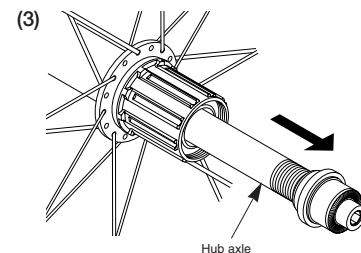

Note:

- When removing and installing the seal, do it very carefully so that the seal does not become bent. When reinstalling the seal, make sure that it is facing the right way, and insert it as far as it will go.
- Do not disassemble the dust-proof cover which is crimped onto the cone.
- The rotor fixing serrations may become damaged if the disc brake rotor has not been installed to the FH-M975, so install the accessory rotor mount cover.

After removing the hub axle, remove the freewheel body fixing bolt (inside the freewheel body), and then replace the freewheel body.

Note:

When replacing the freewheel body, replace the freewheel body fixing bolt at the same time. Be sure to apply grease to the thread of the freewheel body fixing bolt, otherwise looseness or sticking may occur. Do not attempt to disassemble the freewheel body, because it may result in a malfunction.

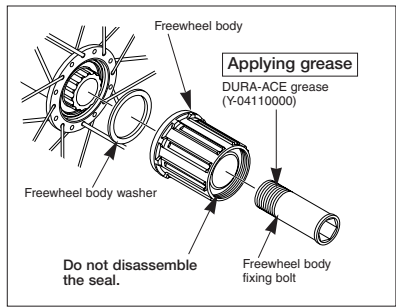
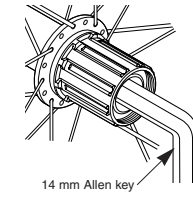

Tightening torque:
45 - 50 N·m {392 - 434 in. lbs.}

<HB-M975 / HB-M970>

Maintenance

The unit can be disassembled as shown in the illustration.

Apply grease to the various parts at periodic intervals.

Note:

- The HB-M975 cannot be disassembled from the left side of the hub unit (the rotor fixing serration side).
- When removing and installing the seal, do it very carefully so that the seal does not become bent. When reinstalling the seal, make sure that it is facing the right way, and insert it as far as it will go.
- Do not disassemble the dust-proof cover which is crimped onto the cone.
- The rotor fixing serrations may become damaged if the disc brake rotor has not been installed to the HB-M975, so install the accessory rotor mount cover.

<HB-M975>

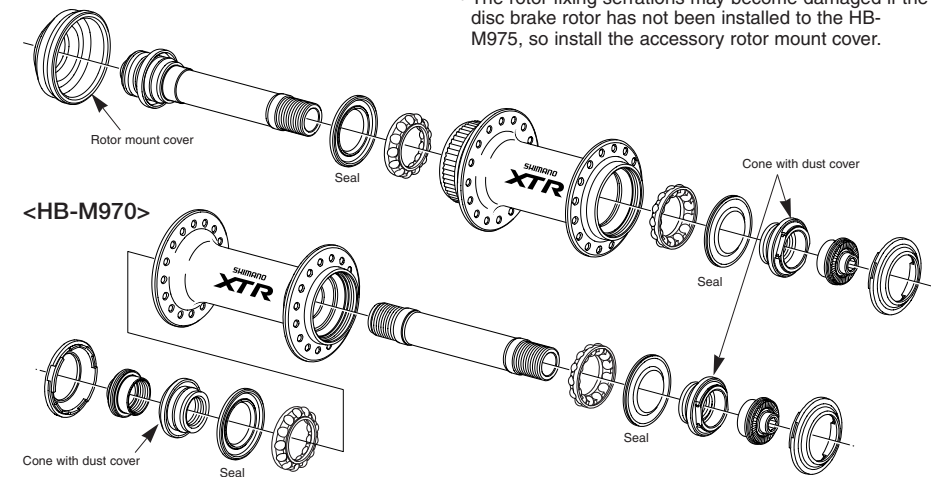

<HB-M970>

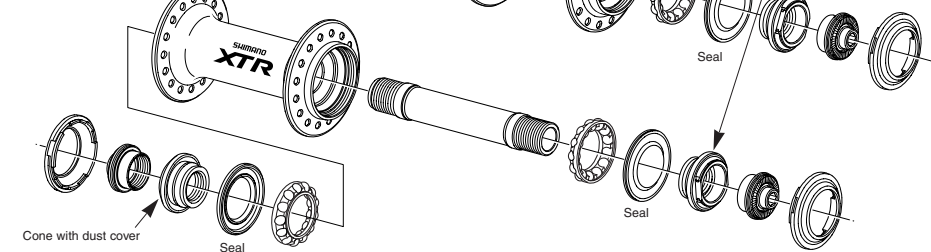

<Assembly>

Use the special tool (TL-HS23 / 18mm) for installing the hub axle and a 5 mm Allen key to tighten the lock nut so as to double-lock the mechanism as shown in the illustration.

Tightening torque:
15 - 17 N·m {132 - 146 in. lbs.}

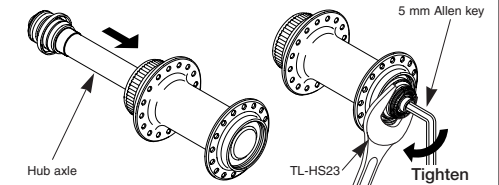

<FH-M975 / HB-M975>

Wheel spoke lacing

Check that the spokes have been laced as shown in the illustration. A radial assembly cannot be used.

Rotating direction of wheel

Front left Rear left Rear right Front right

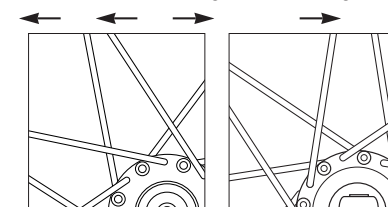

Installation of the rotor (SM-RT97)

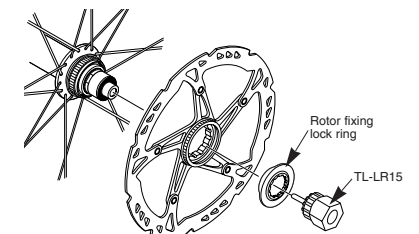

Tightening torque:
40 N·m {350 in. lbs.}